

# *Index*

➤ HOLOGRAPHY

# HOLOGRAM

- A *hologram* is a recording in a two- or three-dimensional medium of the *interference pattern* formed when a point source of light (*the reference beam*) of fixed wavelength encounters light of the same fixed wavelength arriving from an object (*the object beam*). A hologram is a photographic recording of a light field, rather than an image formed by a lens.
- There are many types of holograms, and there are varying ways of classifying them. For our purpose, we can divide them into two types: *reflection holograms* and *transmission holograms*.



# REFLECTION HOLOGRAM

The reflection hologram, in which a truly three-dimensional image is seen near its surface, is the most common type shown in galleries. The hologram is illuminated by a “spot” of white incandescent light, held at a specific angle and distance and located on the viewer’s side of the hologram. Thus, the image consists of light **reflected** by the hologram. Recently, these holograms have been made and displayed in color—their images optically indistinguishable from the original objects. If a mirror is the object, the holographic image of the mirror reflects white light; if a diamond is the object, the holographic image of the diamond is seen to “sparkle”.

## Reflection hologram viewed with white light.

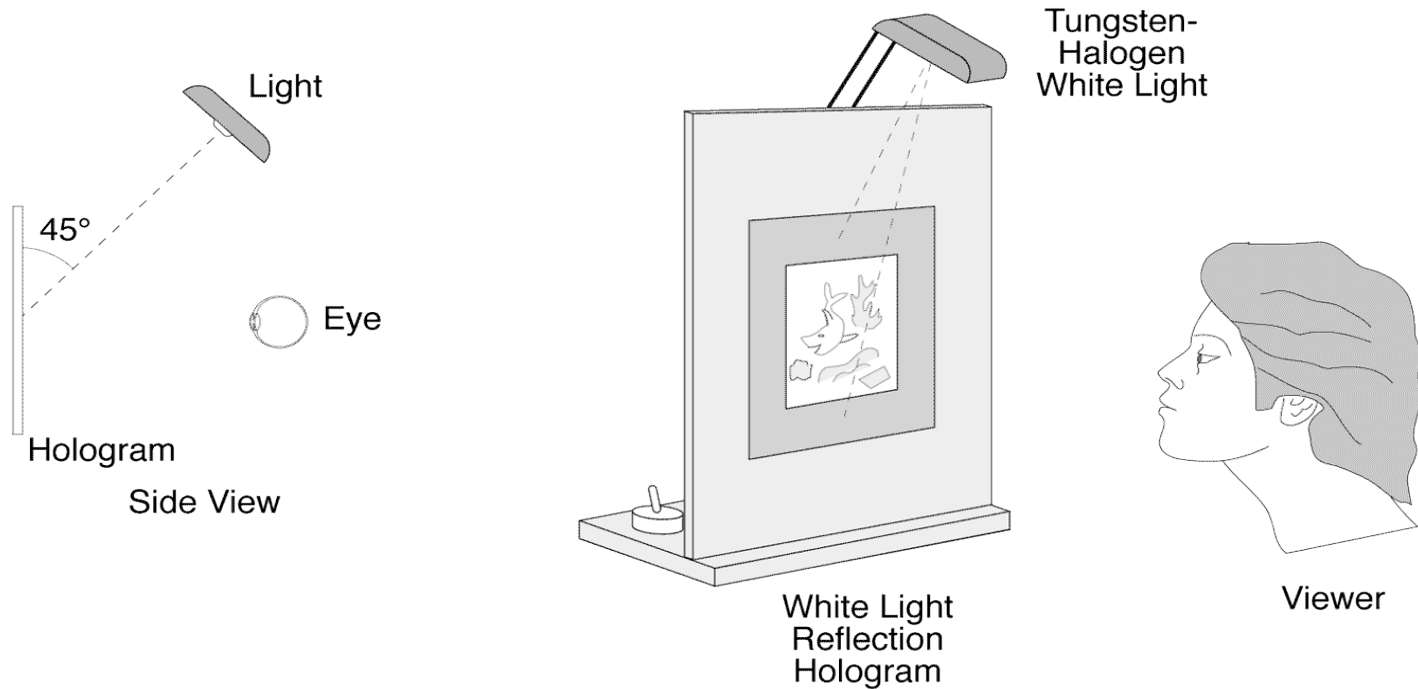

A white-light reflection hologram of a microscope is illuminated with a tungsten-halogen point-source light so that a person can easily view the three-dimensional scene through about 30 degrees of arc. Room lights should be turned off to insure that the hologram is clear without blurry multiple images.

# TRANSMISSION HOLOGRAM

- The typical transmission hologram is viewed with laser light, usually of the same type used to make the recording. This light is directed from behind the hologram and the image is transmitted to the observer's side. The *virtual image* can be very sharp and deep.

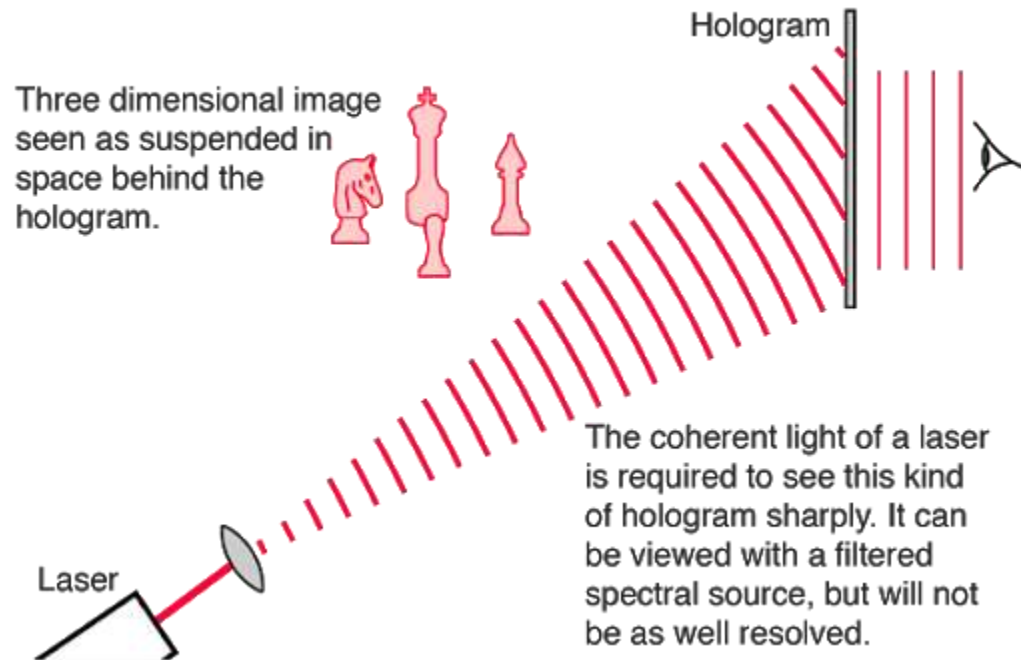

# *Reflection Vs Transmission Hologram*

(i) Reflection holograms form images by reflecting a beam of light off the surface of the hologram. This type of hologram produces very high quality images but is very expensive to create.

(ii) Transmission holograms form images by transmitting a beam of light through the hologram. This type of hologram is more commonly seen since they can be inexpensively mass-produced.

# HYBRID HOLOGRAM

*Between the reflection and transmission types of holograms, many variations can be made.*

Embossed holograms: To mass produce cheap holograms for security application such as the eagle on VISA cards, a two-dimensional interference pattern is pressed onto thin plastic foils. The original hologram is usually recorded on a photosensitive material called *photoresist*. When developed, the hologram consists of grooves on the surface. A layer of nickel is deposited on this hologram and then peeled off, resulting in a metallic “shim.” The shim is placed on a roller. Under high temperature and pressure, the shim presses (embosses) the hologram onto a roll of composite material similar to Mylar.

*Integral holograms*: A transmission or reflection hologram can be made from a series of photographs (usually transparencies) of an object—which can be a live person, an outdoor scene, a computer graphic, or an X-ray picture. Usually, the object is “scanned” by a camera, thus recording many discrete views. Each view is shown on an LCD screen illuminated with laser light and is used as the object beam to record a hologram on a narrow vertical strip of holographic plate (*holoplate*). The next view is similarly recorded on an adjacent strip, until all the views are recorded. When viewing the finished composite hologram, the left and right eyes see images from different narrow holograms; thus, a stereoscopic image is observed.

Holographic interferometry: Microscopic changes on an object can be quantitatively measured by making two exposures on a changing object. The two images *interfere* with each other and fringes can be seen on the object that reveal the vector displacement. In *real-time holographic interferometry*, the virtual image of the object is compared directly with the real object. Even invisible objects, such as heat or shock waves, can be rendered visible. There are countless engineering applications in this field of *holometry*.

Multichannel holograms: With changes in the angle of the viewing light on the same hologram, completely different scenes can be observed. This concept has enormous potential for massive computer memories.

# HOLOGRAPHY

*Holography* is the science of making holograms which are usually intended for displaying three dimensional images. It is a class of methods for recording and reconstructing three-dimensional images, which are based on **interference** phenomena. Holographic images are called *holograms*. Unlike normal photographic images, they do *not* use a mapping of individual objects points to individual points in the hologram; in that sense, they are not images. Instead, light from each image point affects the whole hologram, and each point of a holographic recording affects each reconstructed image detail.

# How Holography Works

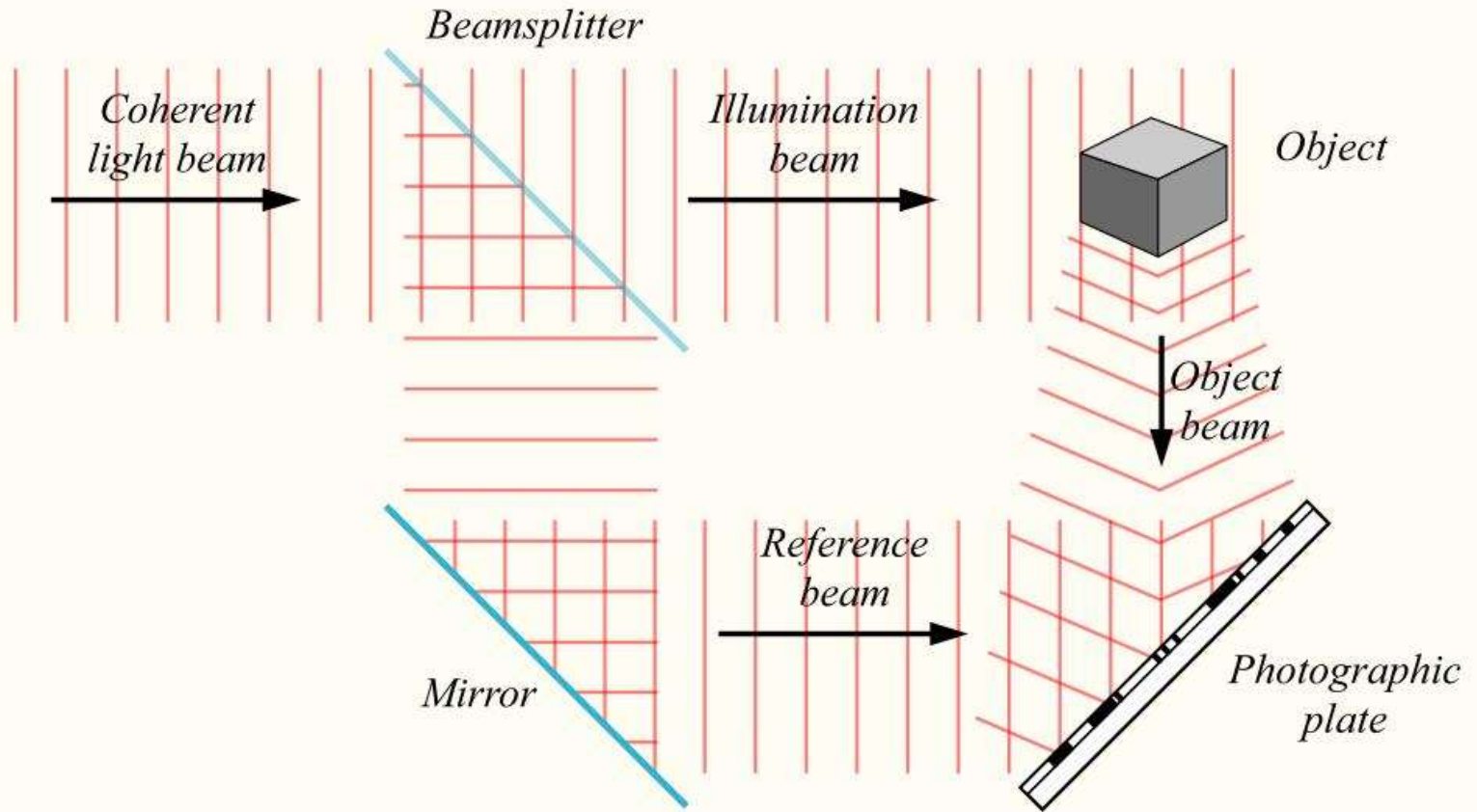

- To create a hologram, you need an object (or person) that you want to record; a laser beam to be shined upon the object and the recording medium; a recording medium with the proper materials needed to help clarify the image; and a clear environment to enable the light beams to intersect.
- A laser beam is split into two identical beams and redirected by the use of mirrors. One of the split beams, the illumination beam or object beam, is directed at the object. Some of the light is reflected off the object onto the recording medium.
- The second beam, known as the reference beam, is directed onto the recording medium. This way, it doesn't conflict with any imagery that comes from the object beam, and coordinates with it to create a more precise image in the hologram location.
- The two beams intersect and interfere with each other. The interference pattern is what is imprinted on the recording medium to recreate a virtual image for our eyes to see.

# *Applications of Holography*

- There are security holograms e.g. for passports, ID cards and credit cards, which are essentially used for making it substantially more difficult to produce convincing illegal copies, since the required replicating technology is hard to procure and expensive, and the details of the required hologram are difficult to measure.
- Despite the typical image imperfections, holograms can be attractive as pieces of art .
- For research purposes, holographic images of tiny objects can be made not only with light, but also with coherent X-rays, as can be generated with **free electron lasers**.

*\* A Shim is a thin piece of metal or composite that is used to fill in space between components, for adjustment of fit, in a mechanical assembly*



## ■ *Experimental Setup*

For creating holograms we need,

- 1) Laser
- 2) Beam splitter
- 3) Photographic plate or Hologram plate
- 4) Mirror

It involves two processes:

- a) Recording a Hologram
- b) Reconstructing a Hologram

# *Recording of a Hologram*

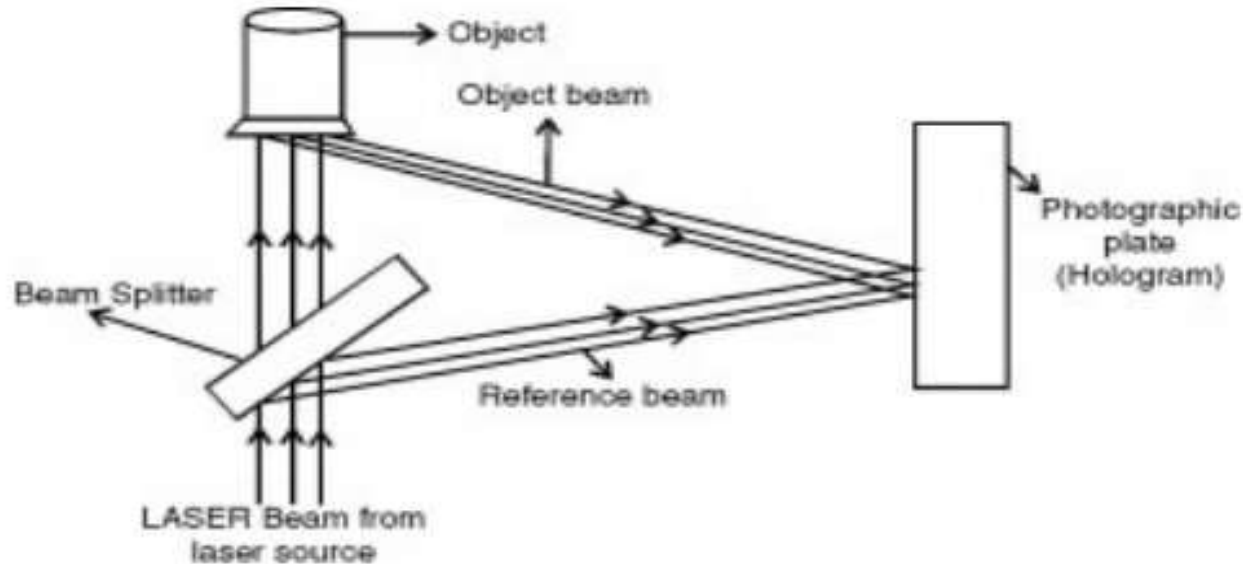

A coherent light from a Laser is directed on a BeamSplitter. A Beam-Splitter divides the laser beam into two identical beams, which are aimed in two different directions. The two beams are Object beam and Reference beam. The object beam is reflected by the surface of the object onto the plate. The reference beam directly falls onto the plate. So the laser beams interfere with each other. A laser light hologram is recorded.

To capture the three-dimensionality of an object, the film stores not only the amplitude but also the phase of the light rays. This recorded interference pattern actually contains much more information than a focused image, and enables the viewer to view a true three-dimensional image which exhibits parallax.

*(\*Parallax is a displacement or difference in the apparent position of an object viewed along two different lines of sight, and is measured by the angle or semi-angle of inclination between those two lines.)*

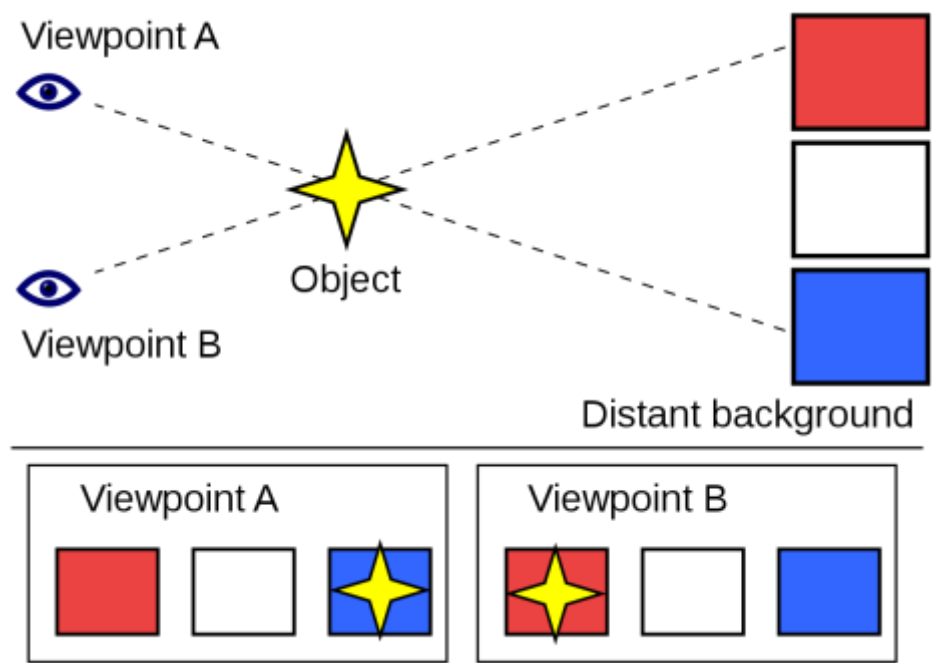

# Reconstructing of a Hologram

■ The laser light hologram can be reconstructed by using the same laser light as for recording. In the reconstruction of hologram, the object beam and the reference beam strike the hologram plate from opposite sides.

To prevent external light from interfering, holograms are usually taken in darkness, or in low level light of a different color from the laser light used in making the hologram. Also, holography requires a specific exposure time, which can be controlled by electronically timing the laser.

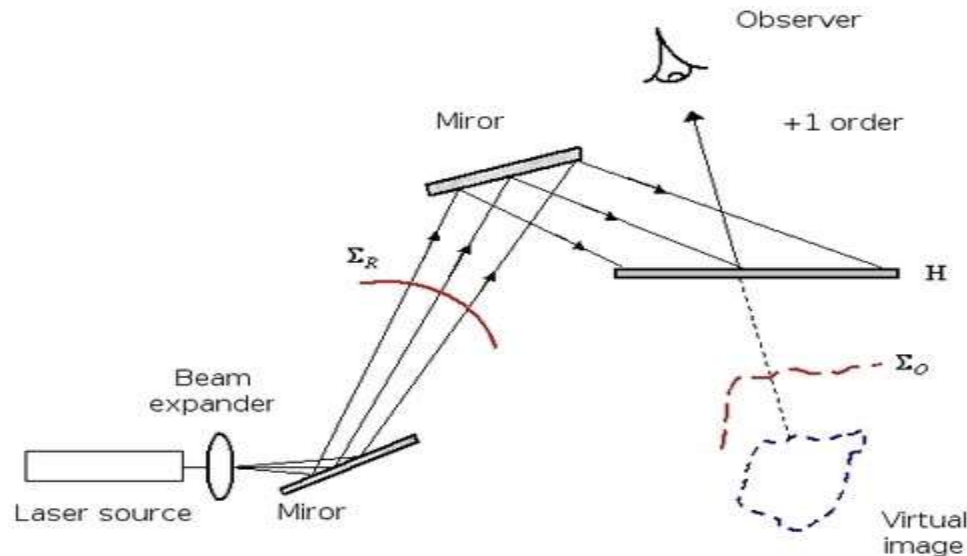

# Theory of Holography between two plane waves

Since any physically relevant wave function can be described as the sum of plane waves and all phenomena involved are linear, the principle of Figure 1 can be generalized to describe any combination of waves.

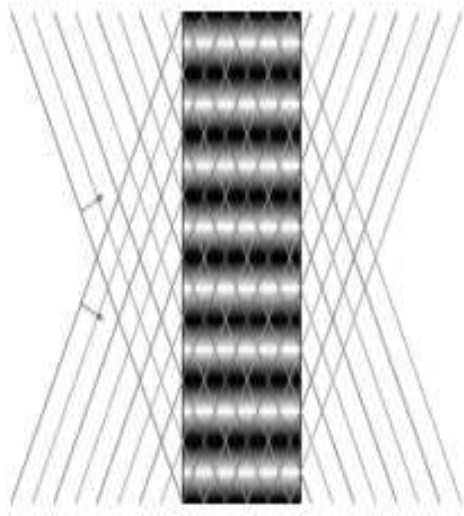

A cutout of the photographic emulsion illuminated by two plane waves. One could be considered as a reference beam and the other as an object beam. Light grey lines represent positive crests and dark grey lines negative crests. In points where two waves interfere constructively the film will turn black and in points where the sum of the two waves always are zero the film will remain transparent after developing. The photosensitive emulsion is several wavelengths thick in a typical film/plate.

*\*A crest is a point on a surface wave where the displacement of the medium is at a maximum.*

# *Point Source Hologram*

Holography is nowadays a highly applied optical technique in many areas of optics and photonics, with applications in diverse areas of sciences such as beam conformation, laser technology and photonic devices, to name a few . In 1948 Denis Gabor proposed a new microscopic method with the objective to improve the image quality and reproduction fidelity of images formed in a conventional microscope . In 1971, Denis Gabor wrote in his Nobel Laureate Lecture that holography is based on the wave nature of light. Indeed, the named Gabor hologram or in-line hologram is based upon the Fresnel diffraction originated by the free propagation of ideal punctual sources, generating the so called Fresnel zone. This diffracted beam is partially coherently superimposed with a reference beam then, forming the interference pattern that constitutes the hologram structure. The reading of the hologram with the reference beam reproduces the wavefront of the original point source. Figure 1 displays a simple scheme for the recording and reproducing of a Gabor hologram, with an ideal point source.

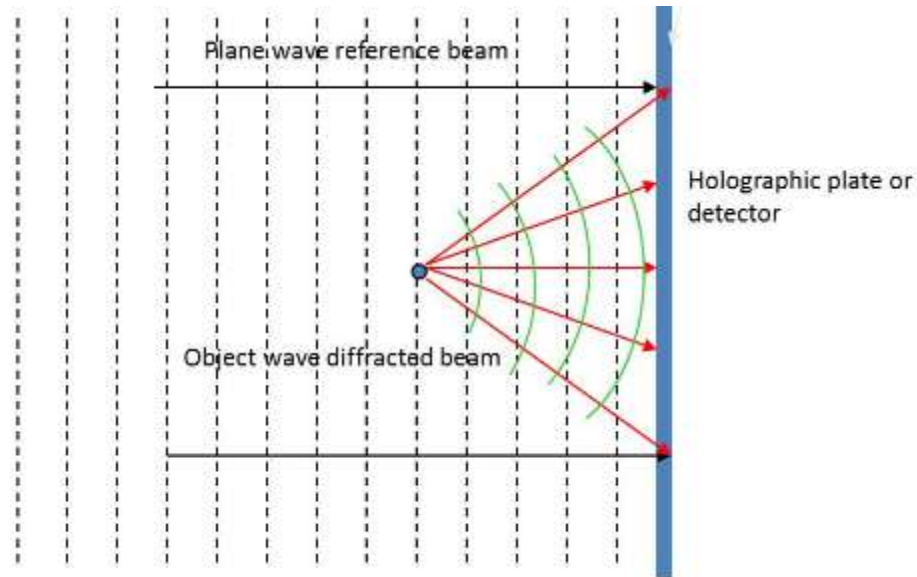
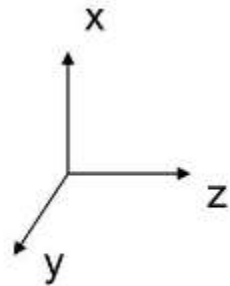

(a)

- (a) *Recording of the hologram of an ideal point source.*
- (b) *Reconstruction, two twin point source images are formed.*

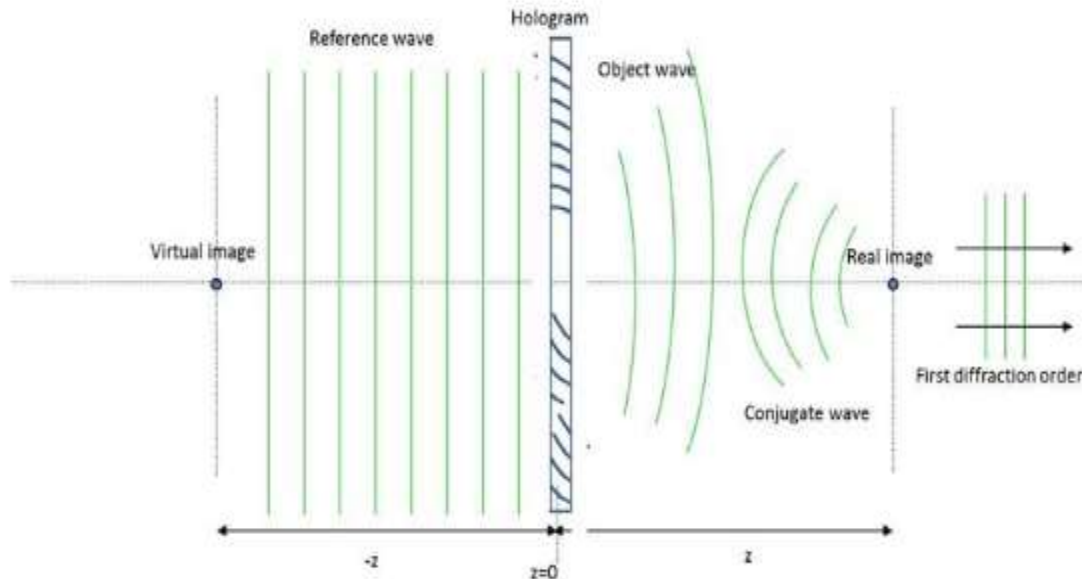

(b)

A schematic more suited for the present work is given in Fig.2

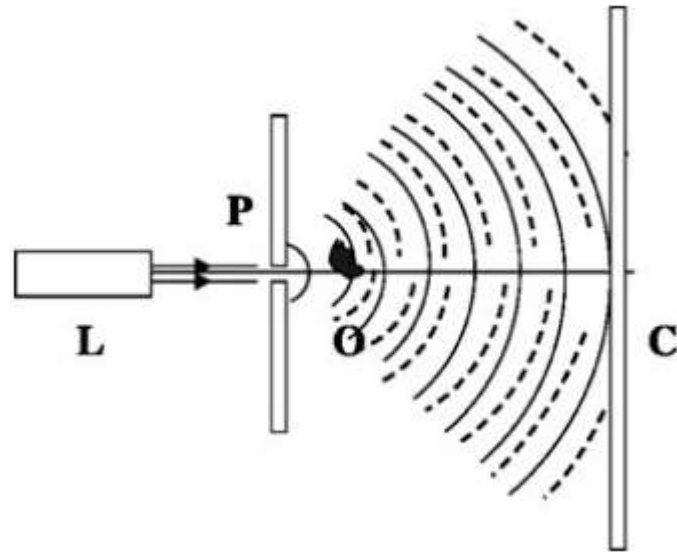

Fig. 2. A laser L is focused onto a pinhole P. The emerging spherical wave illuminates the object O and the interference pattern or hologram is recorded on the screen C. The solid and dashed lines are reference and scattered wave, respectively

The light emanating from the point source is propagating to the screen with some of it being scattered by the object in front of the source. Thus the wave amplitude at the screen is given by

$$A(\mathbf{r}) = A_{\text{ref}}(\mathbf{r}) + A_{\text{scat}}(\mathbf{r})$$

and the intensity recorded on the screen becomes

$$I(\mathbf{r}) = A(\mathbf{r})A^*(\mathbf{r}) = A_{\text{ref}}(\mathbf{r})A^*_{\text{ref}}(\mathbf{r}) + [A_{\text{ref}}(\mathbf{r})A^*_{\text{scat}}(\mathbf{r}) + A_{\text{scat}}(\mathbf{r})A^*_{\text{ref}}(\mathbf{r})] + A_{\text{scat}}(\mathbf{r})A^*_{\text{scat}}(\mathbf{r})$$

The first term on the right is the intensity of the unscattered part of the reference wave; the last term is the intensity of the scattered wave; it is the subject of classical diffraction theory in wave optics. The two terms in the square bracket represent the interference between the reference and the scattered waves. This is called holographic diffraction and is the basis of holography.